

# SEISMIC GEOTECHNICAL INVESTIGATIONS FOR BRIDGES

M. K. Yegian<sup>1</sup>, F. ASCE

## ABSTRACT

Seismic geotechnical investigations for a bridge involve several types of analyses, including: establishment of design level rock motions; site characterization and response analyses; ground and foundation motion computations; assessment of liquefaction and its impact on bridge foundations; soil-foundation interaction and impedance calculations; assessment of foundation performance under the design seismic loads; and in the case of existing bridges, if deemed necessary, design of seismic retrofit measures. The outcomes of each of these various investigations have important implications on the assessment of the overall vulnerability of a bridge. Frequently in engineering practice, “conservative” assumptions are employed at various stages of the investigations with the intent of ensuring that uncertainties are accounted for, and to allow the use of simplifying assumptions and analyses. Whereas a certain level of conservatism should be adopted in geotechnical engineering analyses under static loading conditions, a different approach is warranted for seismic loading conditions. In seismic geotechnical analyses, it is often difficult to discern what the impact of a particular assumption will be on the overall assessment of the vulnerability of a bridge. It is likely that in certain situations perceived conservatisms adopted in the seismic investigations may actually lead to an unconservative outcome. Thus, there are inherent *pitfalls of perceived conservatism* in seismic geotechnical investigations. In this paper, through examples of seismic geotechnical analyses of bridges, a case is made in favor of the application of a *rational* approach. The rational approach is to obtain accurate and site-specific geotechnical information, apply the analysis procedures that most accurately model the specific bridge site and foundations, and employ good professional judgment that is based on a thorough understanding of the fundamentals of soil, foundation, and structural dynamics.

## Introduction

Over the past decade seismic evaluations of bridges in the northeastern United States have received significant attention. Although the seismic hazard in the eastern United

---

<sup>1</sup> Professor of Civil Engineering, Northeastern University, Boston MA, and Geotechnical Earthquake Engineering Consultant.

States is lower than that of the west coast, the large inventory of older and historic bridges in the east are nevertheless vulnerable to earthquake damage. AASHTO (1996) prescribed seismic vulnerability studies for all bridges, including those in the northeastern U.S., using a 500-year event, which is associated with a 10% probability of exceedence in 50 years. In 1998, the New York City Department of Transportation adopted seismic guidelines for bridges that use two levels of seismic design, for critical bridges, an approach more consistent with the practice on the west coast. Today, a major rehabilitation of an existing bridge or the design of a new bridge in the northeastern U.S. will undergo a comprehensive seismic evaluation.

The seismic vulnerability assessment of a critical bridge is a major undertaking. Such an investigation may lead to seismic retrofitting of an existing bridge or enhancements in the design of a new bridge, often at considerable cost. Whether a bridge is deemed to be safe against a seismic event depends on the outcomes of a number of critical investigations. Typically, the scope of a seismic evaluation of a critical bridge will involve the following tasks:

1. Investigation of the seismicity of the region and definition of the potential seismic hazard.
2. Selection of rock motions.
3. Analysis of ground motions and soil response, including liquefaction, slope stability, and earth pressures.
4. Soil-foundation interaction analysis and evaluation of foundation springs and dashpots.
5. Foundation-bridge structure interaction analysis
6. Evaluation of bridge vulnerability, comparison of capacity and demands.
7. Evaluation of bridge foundation vulnerability, checks of stability, comparison of capacity and demand, and deformations.
8. Design of retrofit measures for an existing bridge, or enhancement in the design of a new bridge.

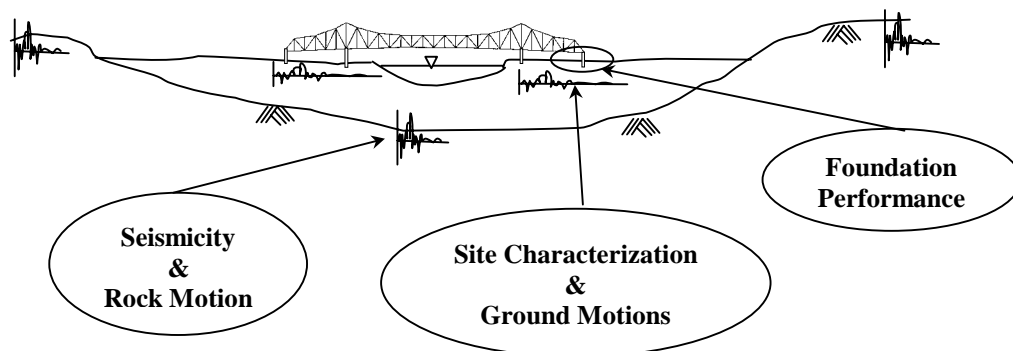
The first two tasks described above fall within the field of seismology. Tasks 3 through 8, with the exception of #6, involve geotechnical earthquake engineering. And finally, tasks 5, 6 and 8 involve the field of structural engineering. The successful application of a seismic evaluation of a major bridge will depend upon rational applications of these various interacting tasks. Often, however, the evaluation follows a fragmented approach, with seismological and geotechnical investigations completed separately and the results provided as input into the final bridge analysis. In such cases, each professional conducting his/her own portion of the investigation sometimes attempts to make conservative assessments and computations of parameters to ensure that uncertainties are accounted for, and to permit the use of simplifying assumptions and engineering analyses. However, it is not always true that such conservatism injected at different stages of the overall bridge analysis will ultimately yield an overall conservative assessment of the seismic vulnerability of a bridge. Ironically, it is likely that in certain situations perceived conservatisms adopted in the seismicity investigations or in the geotechnical and structural analyses may lead to an unconservative outcome.

The seismic response of a major facility such as a critical bridge will depend on the dynamic characteristics of the soil-foundation-bridge system, as well as on the nature of the dynamic excitation. The dynamic characteristics of a soil-foundation-bridge system cannot be defined realistically by evaluating the soil (ground), the foundation and the bridge structure in isolation from each other. In fact, an approach that incorporates apparently conservative decisions in each of the isolated investigations, at times yields unconservative outcomes with regard to the vulnerability of the bridge.

Professor Ralph Peck in 1977 warned against the “Pitfalls of Overconservatism in Geotechnical Engineering”, where compounding of conservative assumptions and decisions may lead to prohibitively expensive designs. Extending this notion of Professor Peck, it can be said that in the seismic design analysis of a major structure, the compounding of what are perceived to be conservative assumptions at various stages of the analysis may actually lead to unconservative outcomes. Thus, in earthquake engineering practice there are *pitfalls of perceived conservatism*, and a case needs to be made in favor of the application of *realistic* assumptions and analytical procedures at each step of the seismic analysis of a major structure such as a bridge.

The author has served as a seismic consultant and been involved in all aspects of the evaluations of many bridges. Based on substantial experience gained from these bridge projects, it is clear that the safe as well as cost-effective new design or retrofit of a bridge requires the application of realistic, not conservative, evaluations at every step of the seismic analysis. This paper presents several case histories of bridge analyses which demonstrate that perceived conservatism can lead to either the under- or over- estimation of soil, foundation and bridge responses, thus demonstrating the pitfalls of perceived conservatism in seismic analysis.

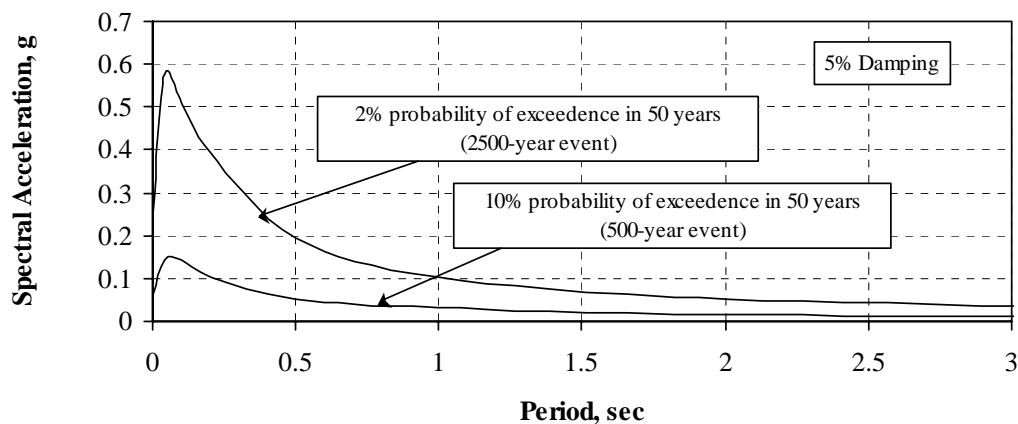
Figure 1 presents a general elevation of a hypothetical bridge project. In the figure, three general areas of seismic investigation are identified; namely; 1-Seismicity and rock motions; 2-Site characterization and ground motions, and 3-Foundation performance. The case history examples presented herein fall within these three general areas of investigation.



**Figure 1. Three general areas of seismic geotechnical investigations discussed in the paper.**

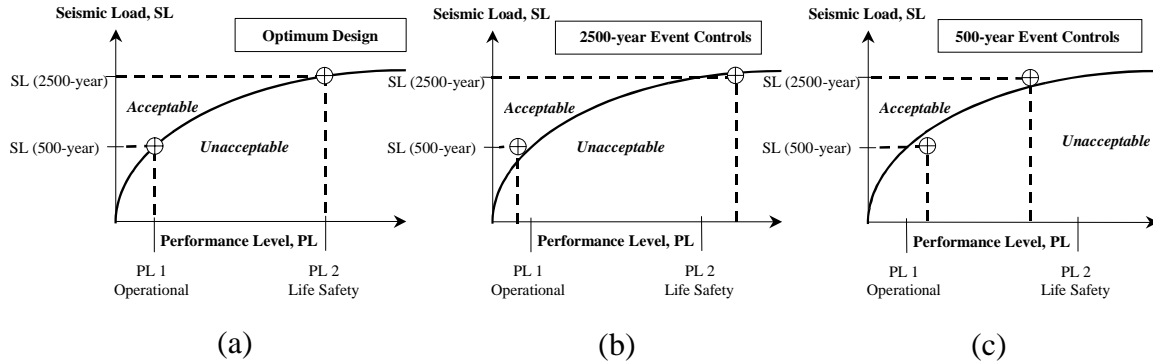
## Seismicity and Rock Motion

In 1998, the NYCDOT adopted a set of seismic guidelines that provide two levels of rock motions associated with 500-year and 2500-year events. Figure 2 shows the acceleration response spectra of the two events on hard rock. The ordinate of the plot in the figure is a measure of the seismic force that a single-degree-of-freedom structure would experience. The response spectra shown, in effect, define the seismic design level inputs at outcroppings of hard rock. These spectra were established using a probabilistic seismic hazard analysis in which the likelihood of seismic events occurring in the region around New York City, as well as the resulting rock accelerations, were statistically combined. A critical bridge is investigated under both the 2500-year and the 500-year events, despite the fact that it may appear at first glance that the 2500-year event, which can induce spectral accelerations about 4 times larger than the 500-year event, should be the one that controls the design. Associated with these two levels of design motions are two different levels of expected performance for the bridge, and therefore it is not actually obvious which event should govern the design.



**Figure 2 The design response spectra for hard rock condition, prescribed in the 1998 NYCDOT seismic guidelines.**

Figure 3a shows a theoretical seismic load versus bridge performance level. Performance level can be defined in terms of bridge movements, or capacity and demand ratios. The stipulation in the NYCDOT seismic guidelines for bridges states that under the 2500-year event the bridge should be safe (no collapse) and repairable within a few days; and under the 500-year event, the bridge should suffer no damage and remain fully operational. The performance criteria under the 500-year event typically also include no cracking of unreinforced masonry, linear structural response, and tolerable movements and permanent displacements in the bridge and its mechanical components, in the case of movable bridges. In an optimal bridge design, the performance criteria for both the 2500-year and the 500-year events are met, as shown in Figure 3a.



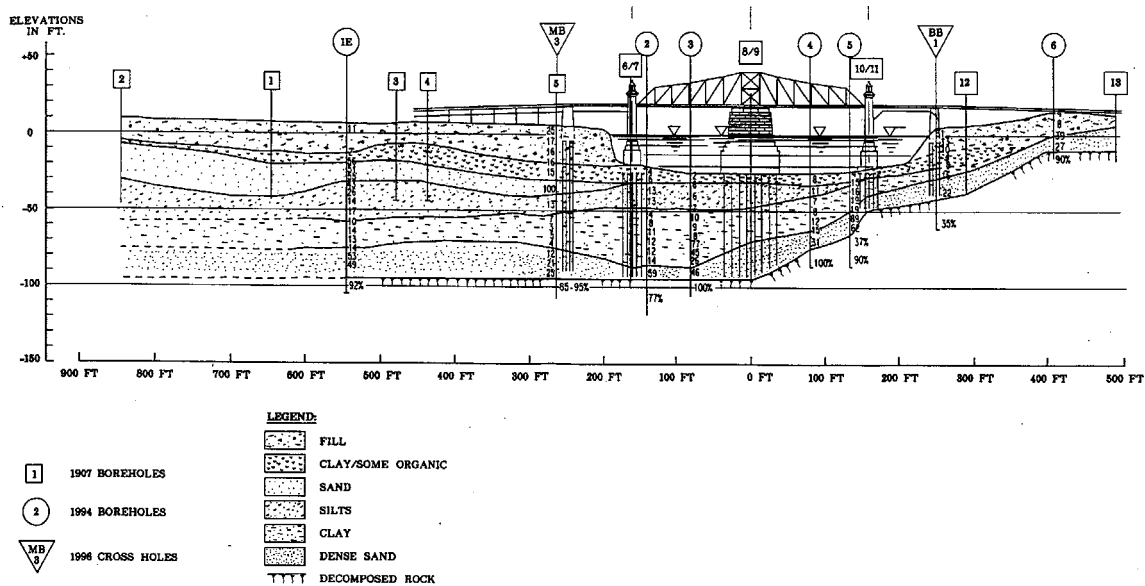
**Figure 3 Seismic event that controls the design based on the expected performance levels, (a) Optimum design, (b) the 2500-year controls, (c) the 500-year event controls.**

Typically, it is not obvious at the start of a bridge investigation which seismic event will be the controlling one. The determination depends on the dynamic response characteristics of the soil-foundation-bridge system, which will define the seismic load levels as well as the bridge performance curve. Figures 3b and 3c show typical situations where either the 2500-year or the 500-year event will control. These figures demonstrate that performing a seismic analysis of a bridge for the 2500-year event alone, which has four times the spectral acceleration of the 500-year event, may not yield a conservative assessment of vulnerability when functionality as well as life safety are required. For this reason, seismic vulnerability is evaluated for both events in the case of critical bridges.

### Site Characterization and Ground Motions

Once the design level rock motions are established for a bridge, the seismic motions within the soil profile and those that the bridge foundations would experience are computed. In addition, the potential for soil liquefaction, slope instability, and dynamic earth pressures may need to be evaluated, depending on the site conditions. In all of these geotechnical investigations, an accurate assessment of the site conditions and the soil and rock dynamic properties are of paramount importance. In this section, case histories are presented which demonstrate the importance of accurate characterization of a bridge site and the use of realistic models for the computation of ground motions.

To demonstrate the importance of the bedrock profile and of choosing the most appropriate type of ground motion analysis, the Madison Avenue Bridge site in NYC was selected. The Madison Avenue Bridge is a swing bridge with a center pier and two rest piers, one each on the Manhattan and Bronx sides. Figure 4 presents the soil profile at the bridge site, and clearly shows the significant spatial variability in the site conditions. The bedrock elevation changes from about -90 ft. on the Manhattan side to about -10 ft on the Bronx side within a distance of about 500 ft.



**Figure 4 The soil profile and elevation of the Madison Avenue Bridge, NY.**

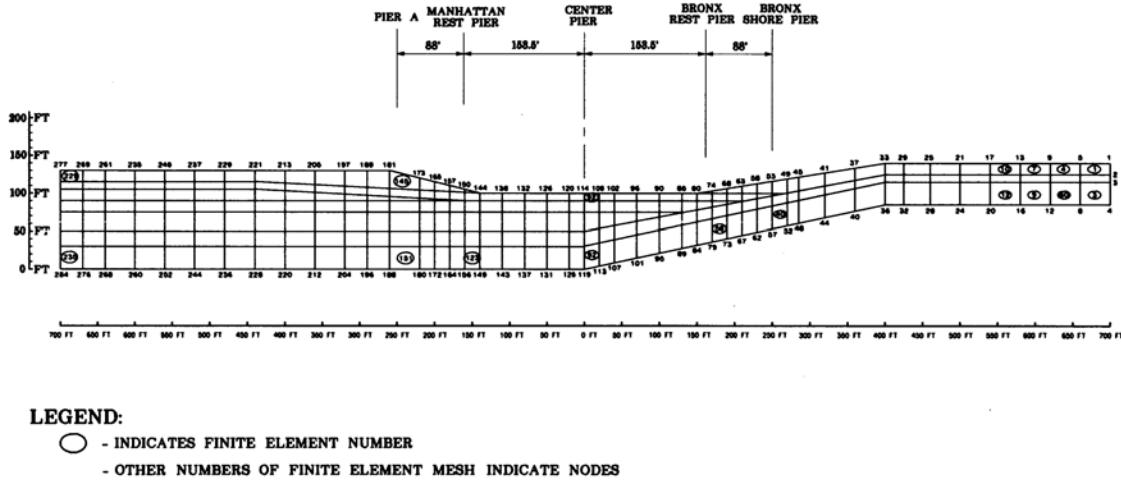
It is well recognized that local site conditions can significantly affect the propagating earthquake motions. In geotechnical earthquake engineering practice, one-dimensional (1-D) wave propagation analysis is typically performed in which a shear wave propagating vertically upward from the base rock to the ground surface is analyzed. To approximately account for spatial variability in site conditions, multiple 1-D analyses are commonly performed for each location of interest, using a soil column that describes the site conditions at that location.

For the Madison Avenue Bridge, this method of accounting for spatial variability in the site conditions was deemed inadequate, considering the sharply dipping bedrock. Ground motions calculated from 1-D analyses of the various bridge pier locations would not have the phase differences associated with the different arrival times of the waves due to the spatially variable geotechnical conditions. For this reason, the finite element procedure was used to determine the influence of the site conditions on the rock motions, and to generate ground motions that were later used in the soil-structure interaction analysis of the bridge.

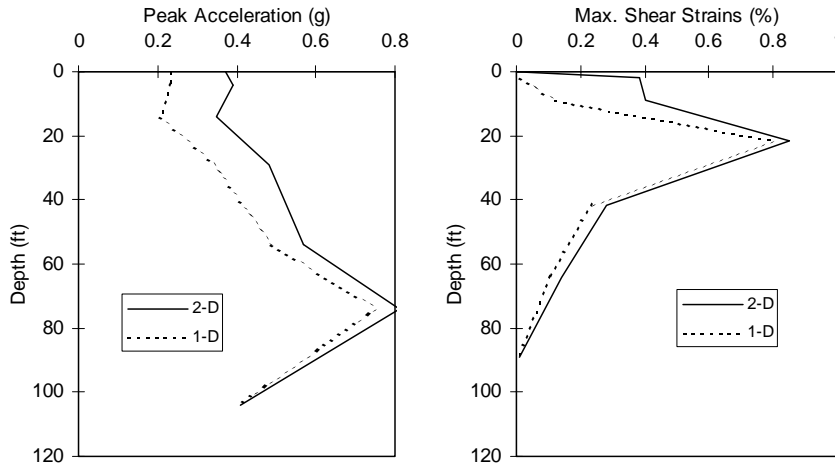
Figure 5 shows the 2-D finite element mesh used. Selected results are presented in which 1-D and 2-D analyses are compared to demonstrate the importance of the 2-D analysis in estimating the magnitude and spatial variation of the ground motions at the Madison Avenue Bridge location.

Figure 6 presents graphs of peak accelerations and maximum shear strains with depth of soil profile at the location of the Manhattan Rest Pier. In this figure, comparisons are made between the results of the 1-D and 2-D wave propagation analyses. Clearly, the 1-

D analysis underestimates the peak accelerations and the shear strains, particularly within the shallow depth of the soil profile. Such underestimation can have important implications on pile lateral stiffness calculations and liquefaction potential.

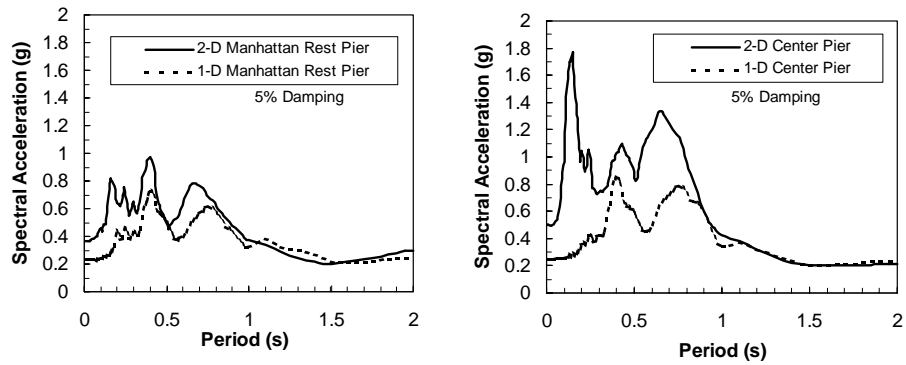


**Figure 5 The finite element mesh used in the ground motion analysis of the Madison Avenue Bridge.**



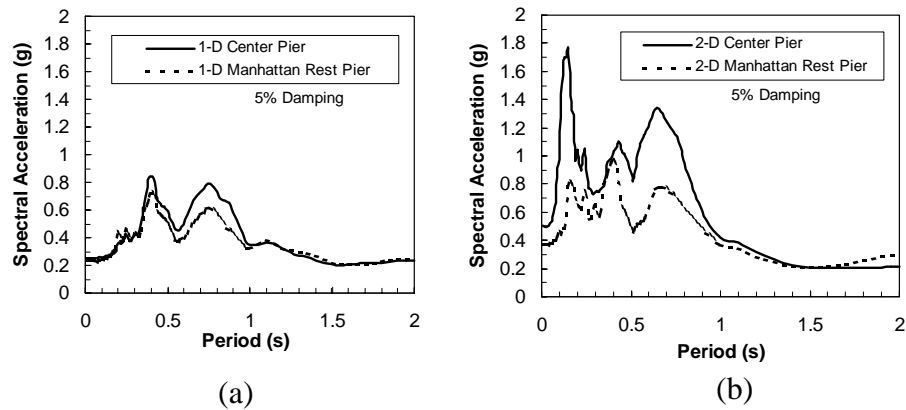
**Figure 6 Comparisons of the peak accelerations and shear strains from 1-D and 2-D ground motion analyses.**

Figure 7 illustrates the effect of 1-D versus 2-D analysis on the frequency content of the computed ground motions at the Manhattan Rest Pier and the Center Pier locations. In this figure, the response spectra of the computed motions from the 1-D and 2-D analyses are compared. The results show that the 1-D analysis significantly underestimates the spectral responses, especially in the period range of interest in the bridge analysis (0.6 sec).



**Figure 7 Comparisons of the spectra from 1-D and 2-D ground motion analyses.**

To illustrate the importance of 2-D analysis in determining spatially variable ground motions, Figure 8 compares the response spectra of the ground surface motions at the Manhattan Rest Pier with those at the Center Pier. In Figure 8a, a comparison is made between the response spectra of the motions from the 1-D analysis at the two pier locations. As expected, since the soil columns at the locations of the Manhattan Rest Pier and the Center Pier are similar, the 1-D analysis yielded similar results for the two piers. Hence, if multiple 1-D analyses were selected to determine the ground motions at these two pier locations, the two piers would be assigned identical motions, i.e. there would be no spatial variability. However, the 2-D analysis results shown in Figure 8b clearly capture the significant differences in the response spectra at the two pier locations.



**Figure 8 Comparisons of the spectra for the Center and Manhattan Rest Piers from (a) 1-D and (b) 2-D ground motion analyses.**

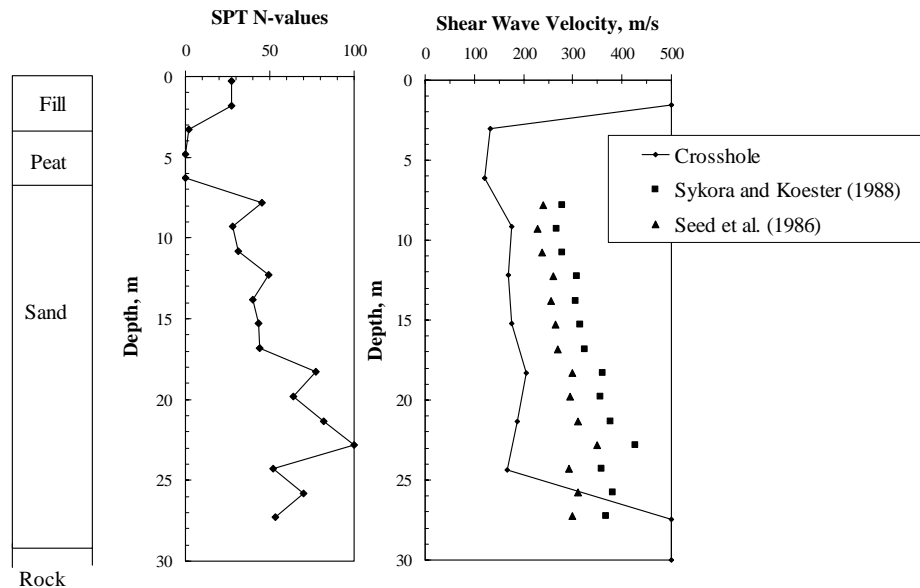
Hence, spatial variability in ground motions due to geotechnical site conditions can be significant, even for relatively short span bridges. In such cases, two-dimensional wave propagation analysis can yield more realistic ground motions than the multiple 1-D

analyses commonly performed. In the case of the Madison Avenue Bridge, 1-D analyses would have underestimated the earthquake effects on the bridge.

To demonstrate the importance of accurately determining the shear wave velocities of the soils for use in the ground motion and bridge analyses, the case of the Third Avenue Bridge over the Harlem River in NYC is presented. One of the most important soil properties used in a dynamic site response analysis is the shear wave velocity,  $V_s$ , of the various soil layers and of the bedrock encountered in a subsurface profile. In geotechnical engineering practice, empirical procedures are often employed that can provide estimates of shear wave velocities for different soils. However, the results of such procedures can be highly uncertain or erroneous. More reliable estimates of shear wave velocities are obtained using field geophysical tests.

One commonly used procedure is the crosshole test, which provides accurate measurements of shear and compressive wave velocities with depth of soil profile. In addition, the crosshole test can be used to measure both the shear and compressive wave velocities of bedrock, parameters that are essential in determining the characteristics of the base rock motion. For these reasons, crosshole tests were conducted at the Third Avenue Bridge site.

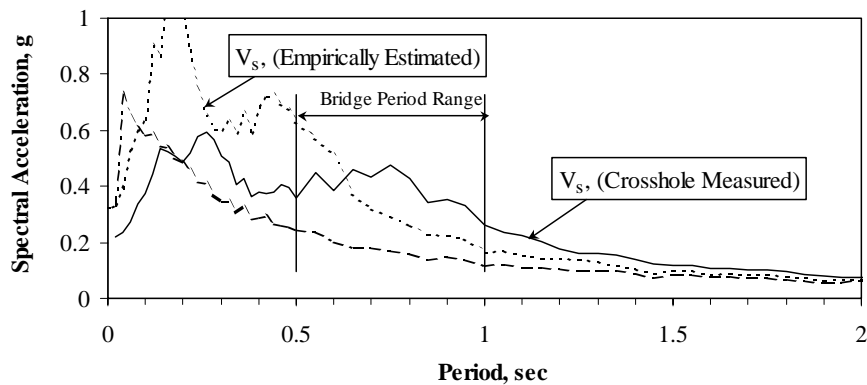
Figure 9 shows the subsurface soil profile at the location of the crosshole test and the SPT N-values recorded. Included in the figure are the shear wave velocity measurements obtained from the crosshole test.



**Figure 9 Comparisons of measured and estimated shear wave velocities.**

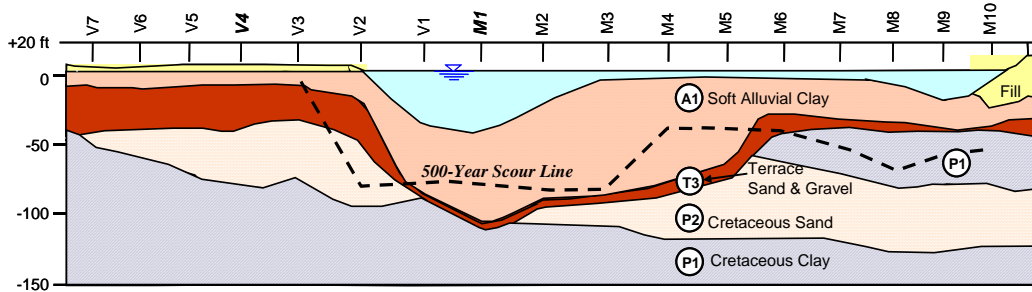
For purposes of comparison, the  $V_s$  values for the soils at the site were also computed using the SPT-N values and the empirical procedures of Sykora and Koester (1988) and Seed et al. (1986). Clearly, the empirical procedures overestimate the shear wave velocities of the soils by a factor of 1.5 to 2. The overestimation is most likely due to the presence of some gravel in the sand layer. In other situations where the silt content is high in sands, the resulting smaller N-values have led to underestimation of the  $V_s$  values. The relevant question in the case of the Third Avenue Bridge, therefore, is whether the use of the empirically-estimated higher values of  $V_s$  instead of the crosshole values would have led to conservative or unconservative seismic loads.

Figure 10 shows the response spectrum of the free-field motion that was computed using the crosshole measured  $V_s$  values. This motion was subsequently used as input in the seismic analysis of the bridge. Included in Figure 10 is the response spectrum of the motion computed using the empirically-estimated  $V_s$  values. There are significant differences between the two spectra. In the period range of a single-degree-of-freedom structure having a period smaller than 0.65 sec, the spectral ordinates (thus, the seismic loads) based on empirically-estimated  $V_s$  values are much larger than those obtained using the crosshole-measured  $V_s$  values. The reverse trend is observed for periods greater than 0.65. The period range of importance for the bridge, including the higher modes of vibrations, was between approximately 0.5 and 1 seconds. Within this period range the empirically-based  $V_s$  values both underestimate and overestimate the spectral accelerations. Hence, using empirically-based  $V_s$  values may lead to either conservative or unconservative seismic loads, depending on the site conditions, the bridge dynamic characteristics, and the seismic input motion at the bedrock level. These factors cannot be evaluated in a cursory manner at the start of a project to determine whether in-situ measurement of  $V_s$  is essential or not. This example clearly demonstrates that for an important bridge project, accurate and realistic measurements of dynamic soil and rock properties are required in order to arrive at a realistic assessment of seismic vulnerability.



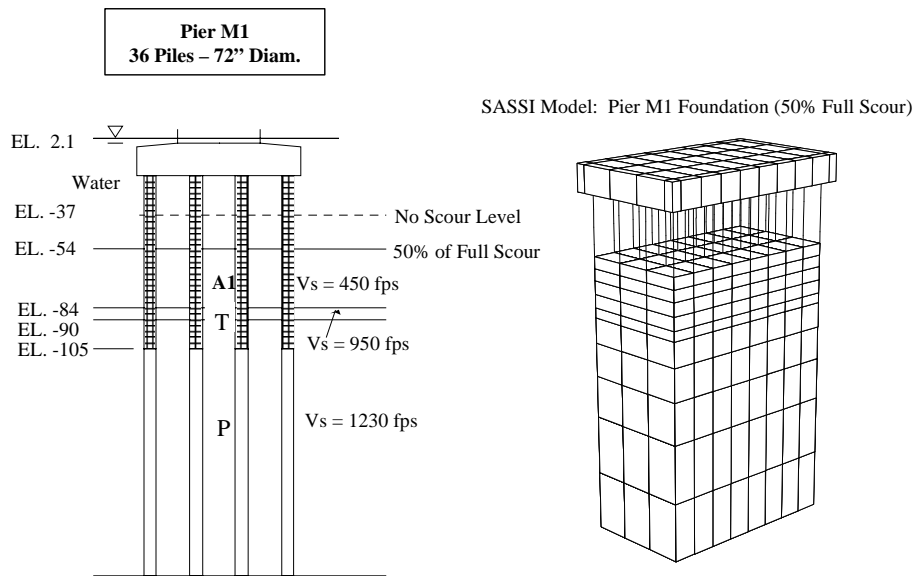
**Figure 10 Comparison of the response spectra from ground motion analyses, using the crosshole measured and empirically estimated shear wave velocities.**

To demonstrate the importance of establishing realistic seismic input motions to a bridge analysis, the case of the New Woodrow Wilson Bridge in Washington, D.C. is presented. Figure 11 presents the soil profile along the bridge axis.

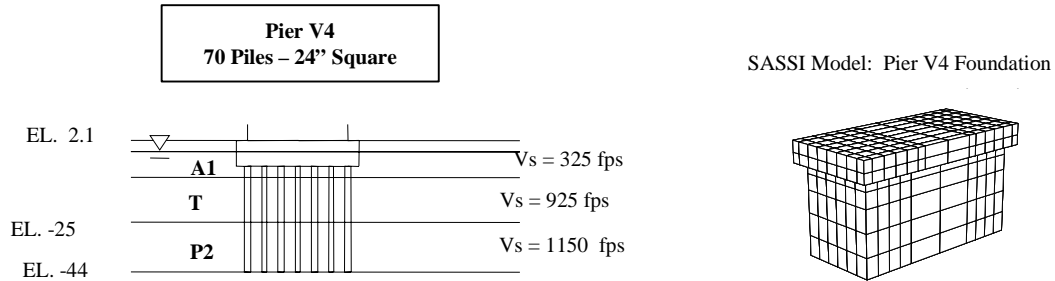


**Figure 11 The soil profile at the site of the New Woodrow Wilson Bridge.**

Although the seismicity of the region is modest, seismic issues were thoroughly addressed in the design of the bridge. The subsurface soil profile consists of about 50 ft of soft or organic clay underlain with a deep deposit of hard sandy clay. The soft clay is vulnerable to significant scour, as shown in Figure 11. The piers of the bridge over the water are founded on frictional and partially-bearing piles. Figure 12 shows the foundation details of the bascule span pier (M1), where the scour potential is high. Figure 13 shows the pile foundation of a typical pier located on land (V4). In this region, the pile cap will be about 10 ft below the ground surface and scour is not a concern.



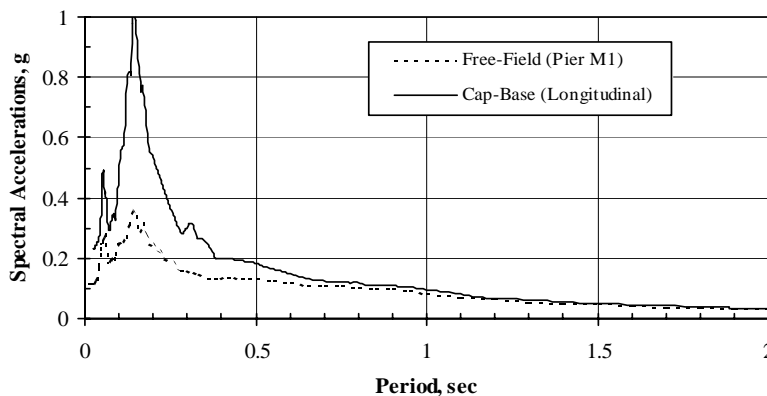
**Figure 12 Pile foundation of Pier M1 and the finite element model used in the 3-D seismic analysis.**



**Figure 13 Pile foundation of Pier V4 and the finite element model used in the 3-D seismic analysis.**

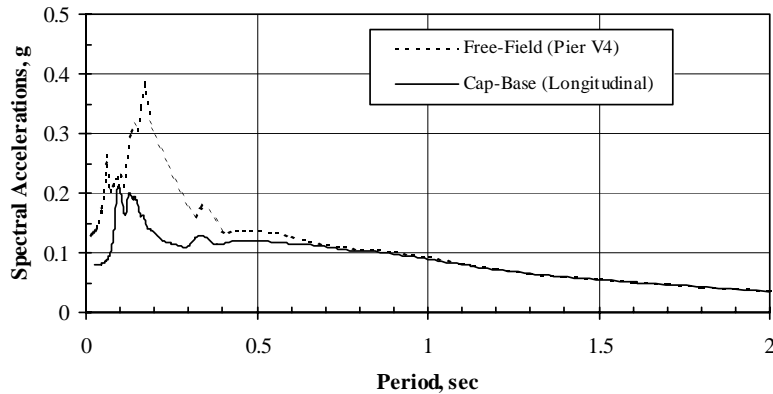
Very often in engineering practice when a pile cap of a bridge pier is embedded a few feet in the ground, the seismic motion at the cap level is approximated by computing the seismic motion in the free field away from the influence of the bridge. Typically, the motion that the cap would experience is slightly smaller than the free-field motion due to the “kinematic effect.” This practice is considered to be a conservative assumption in the estimation of the seismic loads on the bridge. In the case of the Woodrow Wilson Bridge, the M1 pile cap is above the mudline, and V4 pile cap is in the ground. In the bridge analysis, the motions at the base of the pile cap were computed using three-dimensional soil-pile interaction analyses (employing the computer program ACS-SASSI), and then specified as input in the bridge analysis. Below, comparisons are made between the spectra of the motions computed at the pile cap levels and those in the free field that the “conservative” approach described above would yield.

Figure 12 shows the three-dimensional soil-pile model used in the analysis of the pile foundation of Pier M1. The computed spectrum for the M1 pile cap is shown in Figure 14. A comparison of the free-field and cap-base spectra shown in Figure 14 reveals that there is little difference between the spectra for periods greater than about 0.6 sec. In the period range of 0.1 to 0.4 sec, there is a significant increase in the spectral accelerations at the base of the pile cap compared to that of the free field.



**Figure 14 Comparison of spectra of the motions at the Pier M1 pile cap level and in the free field.**

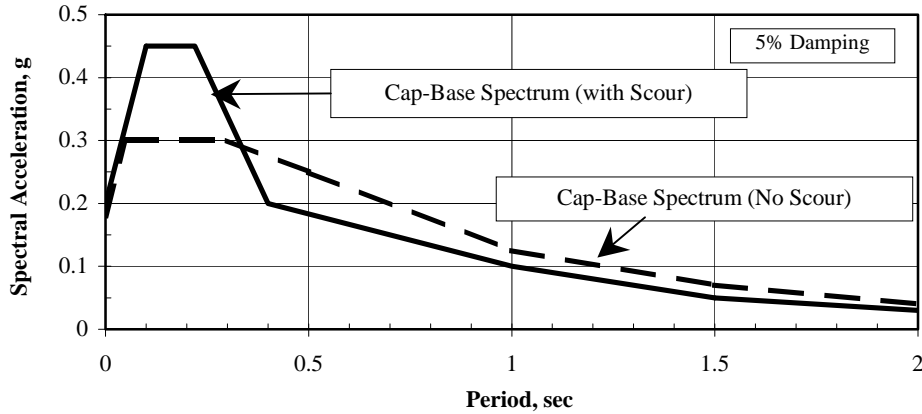
Figure 15 shows the results from the three-dimensional analysis of the pier foundation V4, where the pile cap is on land. It is noted that the response of this pier is quite different from that of pier M1, where the pile cap is in the water. The motion at the cap base is significantly smaller than the free-field motion. Hence, the use of the free-field motions for Pier V4, as is typically done in practice, would have grossly overestimated the spectral accelerations in the period range smaller than 0.4 sec.



**Figure 15 Comparison of spectra of the motions at the Pier V4 pile cap level and in the free field.**

In summary, the results of the soil-pile interaction analyses show that the cap-base motions, particularly in the period range of the soil-pile system, can be significantly different. For foundations with long, unsupported piles penetrating soft clays to a hard stratum, the cap-base motion can be significantly larger than the free-field motion. For embedded pile caps, the cap-base motion can be appreciably smaller than the free-field motion. Clearly, the process of determining the impact of a perceived conservatism (in this case use of free-field motions) on the overall seismic vulnerability of a bridge is not straightforward.

The effect of scour was also investigated in the Woodrow Wilson Bridge analysis. In a static design situation one could convincingly argue that a bridge under static loads is more vulnerable with scour being realized during the life of the structure than without scour. However, under seismic excitations the effect of scour may not be so straightforward. To demonstrate this, the cap-base motions of Pier M1 were computed for both scour and no-scour conditions. The design response spectra established using the computed cap-base motions are compared in Figure 16. As demonstrated in the figure, the effect of scour is to increase the design level accelerations for the period range smaller than 0.3 sec, and to decrease the spectral acceleration for periods larger than 0.3 sec. This effect is only on the cap-base motions. An additional effect of scour is on the stiffness of the soil-pile system. The longitudinal stiffness of the Pier M1 foundation with no scour was estimated to be about  $1.33\text{E}+04$  k/ft. With scour, this stiffness was reduced to  $8.86\text{E}+3$  k/ft. Such reduction in stiffness led to a slightly longer fundamental period of the bridge, and therefore smaller spectral accelerations.



**Figure 16 Comparison of design spectra with and without scour conditions.**

It is noted that the period range of importance in the bridge analysis was greater than 1.0 sec. For the superstructure of the New Woodrow Wilson Bridge, the no-scour conditions where the seismic loads were larger generally controlled. For the foundation design where the pile loads, pile-cap displacements and depth of concrete fill in the pipe piles were of concern, the scour conditions controlled.

Thus, the Woodrow Wilson Bridge project examples demonstrate that what appear to be conservative assumptions, i.e. the use of free-field motions and consideration of scour conditions, may in fact not be conservative. Good engineering requires a more rational approach where the perceived conservative assumptions are avoided, and state-of-the-art engineering practice is followed to the fullest extent possible.

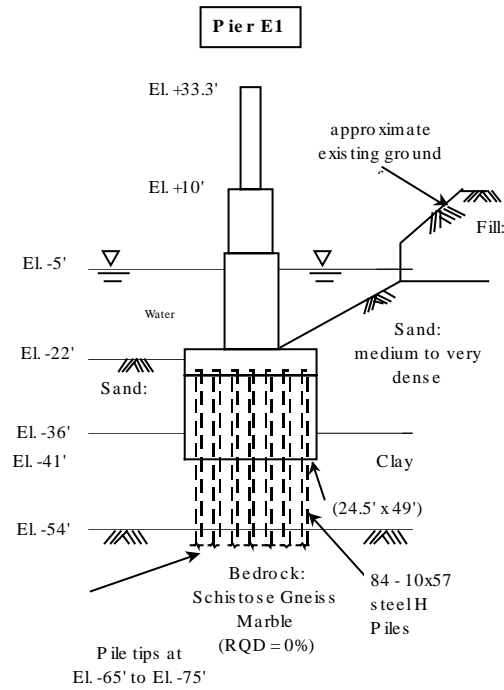
### **Foundation Performance**

In the seismic analysis of a bridge, the soil-foundation system is typically represented through the use of stiffness and damping coefficients (foundation impedances). The forces and moments computed through the seismic analysis are then used to assess the adequacy of the foundations with respect to load capacities and tolerable deformations. The seismic loads that a bridge foundation may experience from the bridge sub- and super-structures will depend, among many other input parameters, on the foundation impedances.

In engineering practice, the calculations of the stiffness of a pile group frequently ignore the contribution to this stiffness by the sides of the pile cap. This practice likely stems from the reluctance in static design to rely on passive resistance (in case in the future it may not be there, or because mobilizing full passive resistance can require deformations that may not be achieved under the design loads). However, under dynamic loads, when a pile cap is rather large and deep, the contribution of the pile cap sides to the overall foundation stiffness and damping can be significant. A stiffer pile cap may also attract

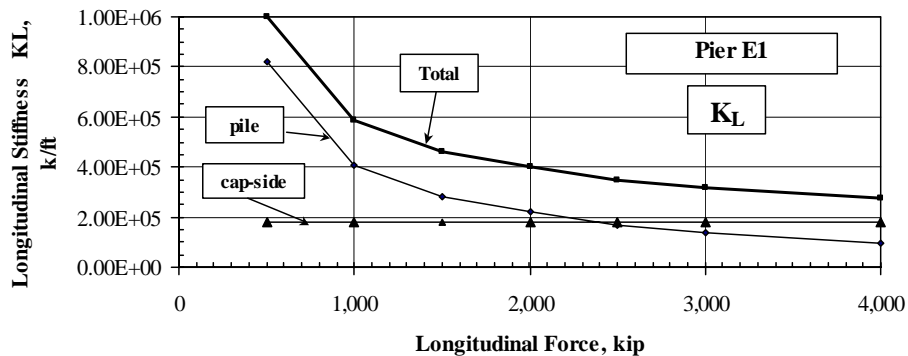
much larger seismic loads. Hence, sides of a pile cap can have an important effect on the overall seismic performance of the foundations of a bridge.

To demonstrate the importance of realistic computation of foundation stiffness, the case history of the Roosevelt Island Bridge, NY is presented. Figure 17 shows one of the important piers of the bridge that is founded on a large pile cap (mostly consisting of tremie concrete), resting on steel H piles.



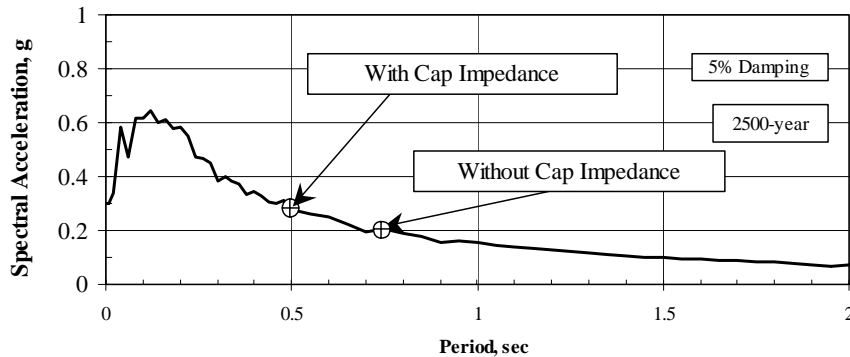
**Figure 17 Elevation of Pier E1 foundation and soil profile of the Roosevelt Island Bridge, NY.**

Figure 18 presents the results of the stiffness calculations showing the contribution to the overall stiffness by the piles as well as the sides of the pile cap.



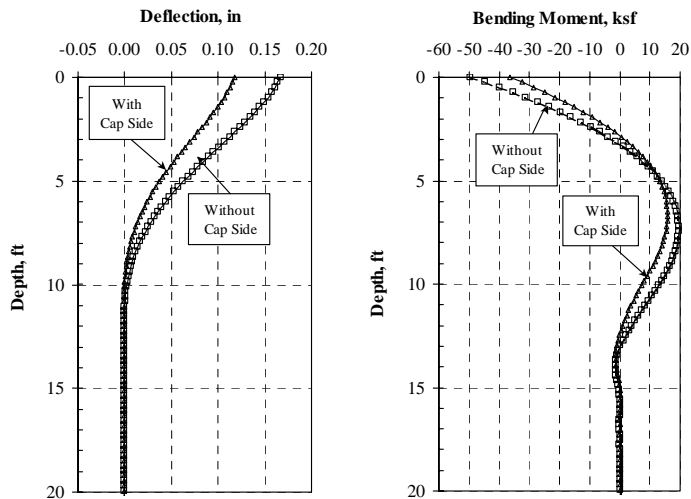
**Figure 18 Contributions of the piles and the pile cap side to the lateral stiffness.**

Under the 2500-year event, the soil-foundation-bridge system had a fundamental period of about 0.5 sec and the pier experienced an average spectral acceleration of about 0.3g. If the contribution of the sides of the pile cap to the overall stiffness of the foundation were ignored, the foundation of the pier would have been more flexible, thus experiencing a smaller spectral acceleration of about 0.2 g, as is illustrated in Figure 19. It appears, therefore, that by underestimating the foundation stiffness, the pile-cap load would be underestimated.



**Figure 19** The effect of pile cap side stiffness on the average spectral acceleration.

Figure 20 shows the results of the analyses of the pile responses using the seismic loads for both conditions: *with* cap-side stiffness, and *without* cap-side stiffness. The results show that although ignoring the cap-side contribution underestimates the stiffness and hence the seismic loads, the result of the smaller stiffness around the pile cap is that the pile cap deflections and pile bending moments are larger by about 50%.



**Figure 20** The effect of including pile cap side resistance on the pile deflections and bending moments.

Hence, in a bridge project it would be very difficult, if not impossible, to predict the result of an underestimation or overestimation of foundation stiffness with respect to foundation performance. The rational approach would be to use good soil and foundation information, reliable analytical procedures and good judgment that is not impaired with perceived conservative assumptions and short cuts.

## Conclusions

Geotechnical earthquake engineering plays an important role in the overall seismic safety analysis of a bridge. The scope of a seismic geotechnical investigation for a bridge may include: establishment of design level rock motion; site characterization and response analyses; ground and foundation motion computations; assessment of liquefaction and its impact on bridge foundations; soil-foundation interaction and impedance calculations; assessment of foundation performance under the design seismic loads; and in the case of existing bridges, if deemed necessary, design of seismic retrofit measures. The outcomes of each of these various investigations can have important implications on the assessment of the overall vulnerability of a bridge. Whereas a certain level of conservatism can be adopted to account for uncertainties and simplified analytical procedures used under static loads, a different approach is required for seismic loads. Under seismic loads, it is often unclear what the implications may be of a particular assumption upon the overall assessment of the vulnerability of a bridge.

To illustrate the potential pitfalls of perceived conservatism in seismic analysis of bridges, case history examples of bridges were presented. It was demonstrated that although a 2500-year seismic event may induce much larger seismic forces on a bridge than a 500-year event, the 500-year event is sometimes more critical. Associated with the two levels of seismic design are different acceptable performance levels for a bridge. The requirement that a bridge be functional during a 500-year event can make this smaller event the one of critical importance, depending on the soil-foundation-bridge system that is being analyzed. Therefore, seismic analyses of important bridges in the northeastern U.S. are performed for both the 2500-year and the 500-year events.

In the case history example of the Madison Avenue Bridge, the 1-D ground motion analysis results compared with those of 2-D analyses *under*-predicted the overall intensity of the motion at the site, and failed to capture the differences in the motions at the different bridge pier locations. In situations where there is significant spatial variation in the site conditions, including sharply dipping bedrock, 2-D ground motion analysis yields more realistic results than the 1-D analysis that is commonly used in practice.

The importance of using reliable estimates of shear wave velocities,  $V_s$  of the soils and bedrock at a bridge site was demonstrated in the case of the Third Avenue Bridge. The acceleration response spectrum of the ground motion computed using the  $V_s$  values that were accurately measured with a crosshole test was compared with that obtained using  $V_s$  values estimated using empirically-based formulas. The empirically-based  $V_s$  values

yielded both overestimated and underestimated spectral values, depending on the period range selected. Reliable determination of ground motions can be made through the use of in-situ measured shear wave velocities.

The example of the New Woodrow Wilson Bridge illustrated the importance of realistically computing earthquake motions for input in the seismic analysis of a bridge. The seismic motions of a pile cap in water (above the mudline) can be significantly larger than the free-field ground motions. Conversely, pile caps in the ground can experience motions much smaller than those in the free field, which are often used as conservative estimates of the seismic motion to the bridge. The effect of scour upon the overall performance of a bridge and its foundation cannot be easily determined at the outset of a project. In the case of the Woodrow Wilson Bridge, both conditions were investigated.

The importance of realistically estimating foundation stiffness was demonstrated through the example of the Roosevelt Island Bridge. Underestimation of stiffness may lead to underestimation of seismic loads on a pile cap. However, even under these smaller loads, the smaller stiffness can result in the overestimation of the pile deflections and bending moments. Thus, the effect of underestimation or overestimation of stiffness on the pile responses can have unpredictable results. The rational approach is to use accurate soil and foundation information, and to use realistic models to calculate reliable values of the foundation stiffness and damping coefficients.

These examples demonstrate that what may appear to be conservative approaches in the seismic geotechnical investigation of a bridge may ultimately yield unconservative results. In many instances it may not be readily obvious what the implications of a given assumption might be on the final outcome of the seismic vulnerability of the bridge. The rational approach is to obtain accurate and site-specific geotechnical information, apply the analysis procedures that most accurately model the specific bridge site and foundations, and employ good professional judgment that is based on a thorough understanding of the fundamentals of soil, foundation, and structural dynamics.

## References

- AASHTO, (1996), 'Standard Specifications for Highway Bridges' Sixteenth Edition.
- ACS-SASSI-C, (1998) "An Advanced Computational Software for 3D Structural Analysis Including Soil-Structure Interaction," ACS, Inc., 38 Harper Dr., Pittsford, New York.
- NYCDOT (1998), "New York City Seismic Hazard Study And Its Engineering Applications". Final Report prepared by Weidlinger Associates for the New York City Department of Transportation, December.
- Peck, R. (1977), "Pitfalls of Overconservatism in Geotechnical Engineering", ASCE Civil Engineering Magazine.
- Seed, H.B., Wong, R.T., Idriss, I.M., and Tokimatsu, K. (1986), "Moduli and Damping for Dynamic Analyses of Cohesionless Soils", ASCE, Journal of the Geotechnical Engineering, 112(11).

Sykora, D.W. and Koester, J.P. (1988), "Correlations Between Dynamic Shear Resistance and Standard Penetration Resistance in Soils", Earthquake Engineering and Soil Dynamics II, ASCE Geotechnical Special Publication No. 20.

### **Acknowledgments**

The author is indebted to the many colleagues with whom he has collaborated on the projects referenced herein, including:

**Mr. Henry Perahia**, Deputy Commissioner/Chief Engineer Division of Bridges, **Mr. Kamal Kishore**, Deputy Chief Engineer, Engineering Review and Support, **Mr. Jay Patel**, Deputy Chief Engineer, East River bridges/Movable bridges, **Mr. Tom Cocola**, Assistant Commissioner, Public Affairs Office, and **Mr. Sajjan Jain**, I/Director Engineering Support, from the New York City Department of Transportation, for their review and approval of the articles on the Madison Avenue Bridge, the Third Avenue Bridge, and the Roosevelt Avenue Bridge.

**Andrew Coates**, **Beile Yin**, **Paul Connolly**, **John Pizzi**, and **Frank Marzella**, from Hardesty & Hanover for the Third Avenue Bridge, and the Roosevelt Avenue Bridge.

**Serafim Arzoumanidis**, from PARSONS, for the Madison Avenue Bridge, and the New Woodrow Wilson Bridge.

**Sissy Nikolaou** and **Roderic Ellman** from Mueser Rutledge Consulting Engineers for the New Woodrow Wilson Bridge.